

INSTALLATION GUIDE

Lower control arm – camber adjuster kit

ZW53457

1. Remove control arm as per workshop manual
2. Remove control arm pivot bushes from subframe
3. Retain / replace original through bolts , nuts and washers
4. Clean and inspect eyes in subframe
5. Install bushings as per factory specification
6. Lubricate inner diameter (ID) and end flanges of each bush with supplied grease
7. Lubricate outer diameter (OD) and inner faces of pivot tubes
8. Offer control arm into gap between bushes and insert eccentric pivot tubes from each direction. Take care to ensure small offset nose of each pivot tube is in same plane so as both will engage control arm
9. Install through bolt, washers and nuts
10. Reassemble suspension as per workshop manual
11. Using 2 spanners rotate pivot tubes to desired camber settings
12. Complete wheel alignment and road test
13. Retorque through bolts after road test

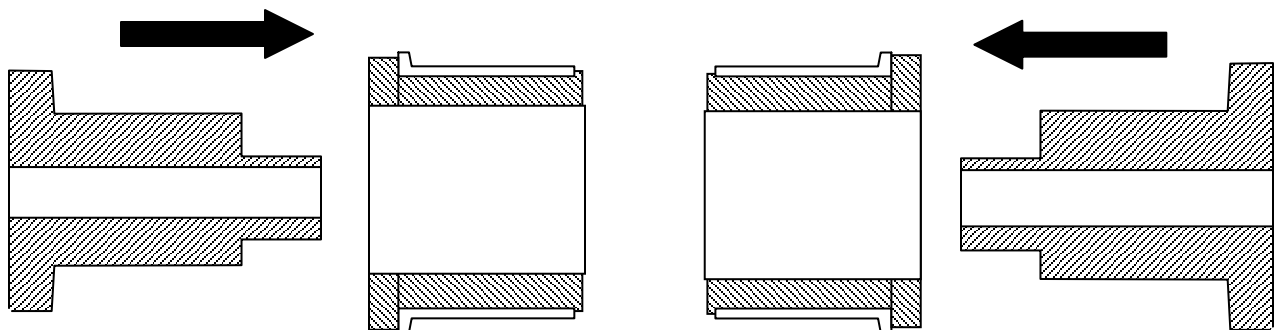

This procedure must be carried out by a qualified person