

Instructions

Rear Trailing Arm Bushings

N.B: This instruction sheet should be used in conjunction with the workshop manual and proper safety procedures followed.

- Raise vehicle evenly and safely support.

Never rely on a Jack only

- Proceed to remove rear wheels.
- Remove hand brake bracket.
- Remove rear ball joint nut and front bushing bolt. Careful to not damage aluminium components.

Remove arm from vehicle.

Note - a Press will be required to replace the bushing.

- Using appropriate Press Tools, push out original bushing including steel outer shell.
- Push in new bushing. This is best done with with flat surfaces and soapy water.
- Grease bushing internal diameter and face with supplied grease only.

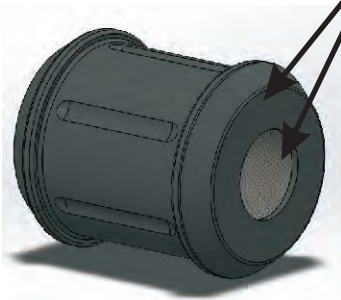

- Push in supplied steel tube.
- Re-fit arm to vehicle - tighten bolts to 75Nm.

Application - Mitsubishi EVO

Always refer complete catalogue listing

Contents - 2x 1-piece bushings
 - 2x Steel tubes 25.4x14.3x70
 - Grease



Lower Trailing arm and bushing

N.B: It is recommended that a licenced workshop or tradesperson carry out the above procedure and that workshop manual and relevant safety procedures are followed in addition to the above.