

# Front upper control arm bushes

## Application:

### - Ford Falcon FG Series

Always refer to current catalogue for complete application listing.

## Contents:

- 4 x 67057 Bushes
- 4 x Crush tubes
- 1 x Grease sachet

## Fitting Instructions:

Please read complete fitting instructions and check kit components prior to fitment. These instructions are to be used in conjunction with the workshop manual, and it is recommended that all work be carried out by a qualified technician.

1. Raise and support the vehicle on chassis stands.
2. Remove the road wheels from the vehicle.
3. Remove the upper ball joint clevis bolt from the knuckle .
4. Gain access to the inner control arm bracket mount nuts either through the engine bay or from underneath the vehicle and remove.

**Note:** In most instances these nuts will need to be loosened off or removed to allow the control arm bolt to be removed from the vehicle.

5. Remove the control arm bolts and remove the upper arm from the vehicle.
6. Before removing the bushes from the arm mark the position of the key ways on the arm to aid in correct installation of the 65057 bushes.
7. Remove the OE bushes from the arm and inspect arm for damage. Repair or replace as necessary.
8. Install the supplied 67057 bushes into the arm making sure the larger flange face faces outward and the bush is timed correctly (refer fig 2.)

**Note:** This can be identified by the **OUT** mark stamped on one end of the bush.

9. Apply a liberal amount of grease supplied to the outer flange faces of the bush and re-fit the arm into the brackets.
10. Re-fit the arm back into the vehicle and torque all bolts to manufacturers specifications.
11. Carry out wheel alignment.

**Note:** It is recommended to re-tension all bolts in approx 100km's of distance travelled.

Fig 1.

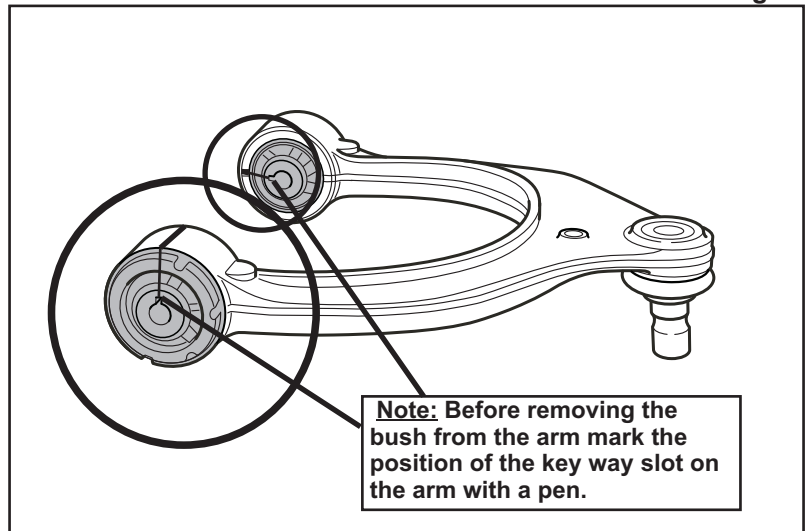

Fig 2.

Please note voiding orientaion as per below image.

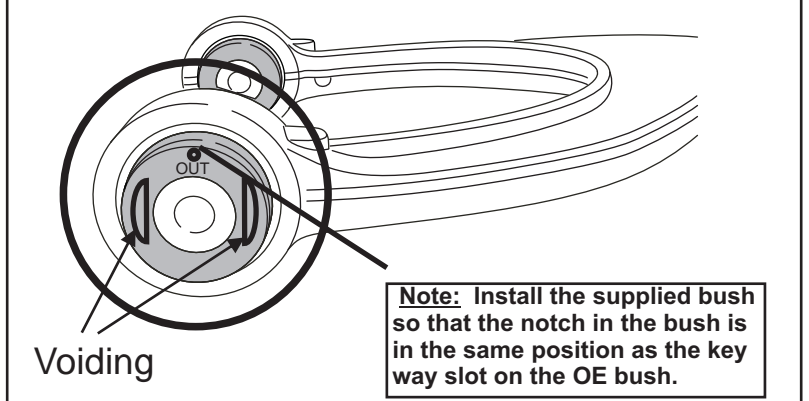

Fig 3.

